

# “Implementation of CC-CV Battery Charging Method with Temperature Control for Level Crossings”

Yuli Prasetyo<sup>1</sup>, Santi Triwijaya<sup>2</sup>, Andri Pradipta<sup>3</sup>, Akhwan<sup>4</sup>, Akhsay Chandra Dewanta<sup>5</sup>, Aggie Brenda Vernandez<sup>6</sup>

<sup>1</sup>Madiun State Polytechnic,

<sup>2,3,4,5</sup>Indonesia Railway Polytechnic,

<sup>6</sup>Semarang State Polytechnic

Jl. Serayu, Pandean, Madiun City, INDONESIA

Jl. Tirta Raya, Madiun City, INDONESIA

Jl. Prof. H. Soedarto, S.H., Kec. Tembalang, Semarang City, INDONESIA

---

## Article Info

### Article history:

Received December 25, 2025

Revised March 12, 2026

Accepted March 30, 2026

### Keywords:

Batteries

Level crossing

CC-CV

Charging

Temperature

---

## ABSTRACT (10 PT)

Level crossings are critical for ensuring the safety of long-distance railway operations. To maintain the reliability of these at-grade crossings, their power supply systems are equipped with lead-acid batteries. This study focuses on the battery charging system. A known effect of battery charging is temperature rise due to charge current flow. To resolve the charging time problem at level crossings, this research proposes Constant Current – Constant Voltage (CC-CV) method, which also regulates temperature to extend battery lifespan. Battery charging tests were conducted by comparing the CC-CV and Switch Mode Power Supply (SMPS) methods, starting from the minimum battery voltage (11.72 V) until the voltage set point was reached. The results show that the SMPS method required 5 hours with an average charging temperature of 34.0°C. In contrast, the CC-CV method required only 2.1 hours with an average temperature of 35.4°C. Therefore, the CC-CV method can significantly accelerate the charging time while ensuring the temperature remains within the specified maximum limit. This shorter charging duration is expected to enhance the reliability and prevent service disruptions at level crossings.

---

### \*Corresponding Author:

Santi Triwijaya, S.T. M.T.

Department of Mechanical Engineering, Indonesian Railway Polytechnic

Jl. Tirta Raya, Pojok, Nambangan Lor, Manguharjo, Madiun, Jawa Timur 63161, Indonesia

Email: [santi@ppi.ac.id](mailto:santi@ppi.ac.id)

---

## 1. INTRODUCTION

Level crossings are critical safety interfaces between railroad tracks and roadways [1]. Their safety is highly dependent on the reliable operation of warning devices, such as flashing red lights, sirens, and automatic gates[2], [3], [4]. The electrical systems of these devices, including the DC/AC motors responsible for lowering and raising the gate barriers, are powered by battery supplies. Crucially, without power from the battery, the gates will remain inoperative even if the train detection system is active, creating a significant safety hazard[5].

Various types of batteries are utilized at level crossings in Indonesia, with lead-acid batteries being one of the most common. Due to their reputation for dependability and rugged operation, lead-acid batteries

are widely adopted in applications including electric vehicles, renewable energy storage, and industrial machinery [6]. However, a primary challenge in their utilization is maintaining efficiency and extending service life through an appropriate charging process [7].

In principle, batteries are charged by applying continuous current until the voltage reaches a maximum threshold [8]. Continuing to charge beyond this point can lead to energy waste, excessive heating (*overheating*), and a shortened battery lifespan. Consequently, an effective and efficient charging method is key to optimizing the performance and durability of lead-acid batteries.

Several mechanisms in battery charging include the conventional Switch Mode Power Supply (SMPS) and the CC-CV method. The SMPS method is generally designed to produce a constant output voltage by regulating the switching process based on voltage feedback from the output side [9]. In this system, the amount of current flowing depends on the characteristics of the connected load. If the load requires a larger current, the output current will increase until it reaches the power source's capacity limit or until the protection system operates [10]. In contrast, the SMPS with the CC-CV method is able to regulate the output current and voltage in a controlled manner through two operating modes [11], [12]. In the initial stage, the system works in CC mode to maintain a stable current, then switches to CV mode after the voltage arrives a certain magnitude.

CC-CV method is a commonly used charging technique. This method begins with CC phase until a set point voltage is reached, then switches to a CV phase until the charging current drops to a low level [13]. It aims to reduce charging time and prevent overcharging [14]. However, charging with a relatively high, constant current carries the risk of causing a significant temperature to rise in the battery [15].

A major issue associated with lead-acid battery charging is temperature management. Excessive heat during charging can cause electrode material degradation, electrolyte evaporation, and in extreme cases, a risk of explosion [16]. Therefore, implementing a temperature cut-off system is crucial to maintain a safe temperature range and prevent overheating [17].

Based on this background, this research aims to develop a CC-CV-based lead-acid battery charging system prototype equipped with a temperature cut-off mechanism. This mechanism allows the system to automatically halt charging when the battery temperature exceeds a predetermined threshold, thereby preventing damage and enhancing operational safety. The integration of the CC-CV method with temperature control is expected to significantly improve charging efficiency and extend battery life.

## 2. RESEARCH METHOD

To support this research, a device was designed and constructed to apply the CC-CV method while accounting for battery temperature during charging at the level crossing. Subsequently, data was collected from the device for performance evaluation. Electrically, the device utilizes a 220 V AC power source, which is stepped down to 12 V DC to supply the buck-boost converter module serving as the core charging regulator. This 12 V supply is further stepped down to 5 V DC using an LM2596 regulator to power the microcontroller. The charging parameters—namely current, voltage, and battery temperature—are monitored in real-time and displayed on a 16x2 LCD screen. Battery voltage is read using a voltage divider circuit sensor, while the charging current is measured with an ACS712 sensor. Battery temperature is monitored using a MAX6675 temperature sensor module. The complete block diagram of the designed system is presented in Figure 1. This system is the hardware implementation of the previously described algorithm. The Arduino processes data from the sensors, then controls the buck-boost converter to execute CC-CV charging, while simultaneously monitoring temperature via the MAX6675. If the temperature exceeds the limit, the Arduino commands the Relay to open the circuit to stop charging, thereby protecting the battery from overheating.

Figure 2 details the logical workflow of the implemented battery charging algorithm, which integrates CC-CV method with a critical temperature-based safety cut-off. The process initializes by reading the battery's starting voltage, current, and temperature. It then enters the CC phase, maintaining a fixed charging current until the battery voltage reaches a predefined set point of 11.72 V. Upon reaching this threshold, the algorithm transitions to CV phase, where the voltage is held constant at 11.72 V. This allows the battery to safely approach full capacity as the charging current naturally tapers, eliminating the risk of overvoltage. Through both charging phases, the system continuously monitors the battery temperature. A primary safety feature is activated if the temperature exceeds the maximum safe limit of 37°C. In this event, the system commands a normally open (NO) relay to disconnect the charging circuit, immediately and automatically halting the process to prevent overheating and protect the battery's integrity.

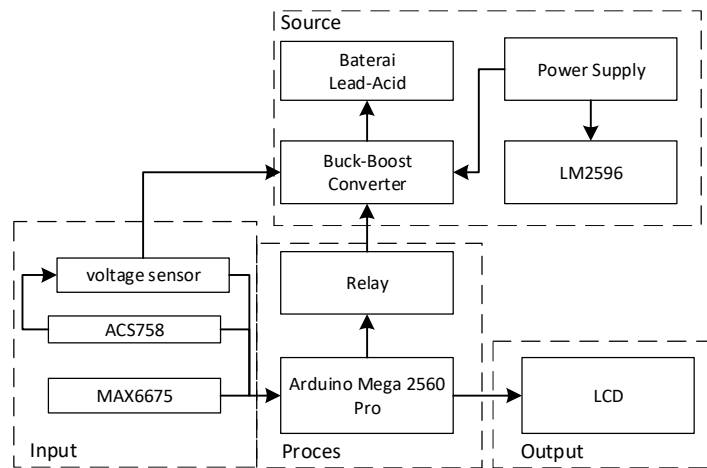
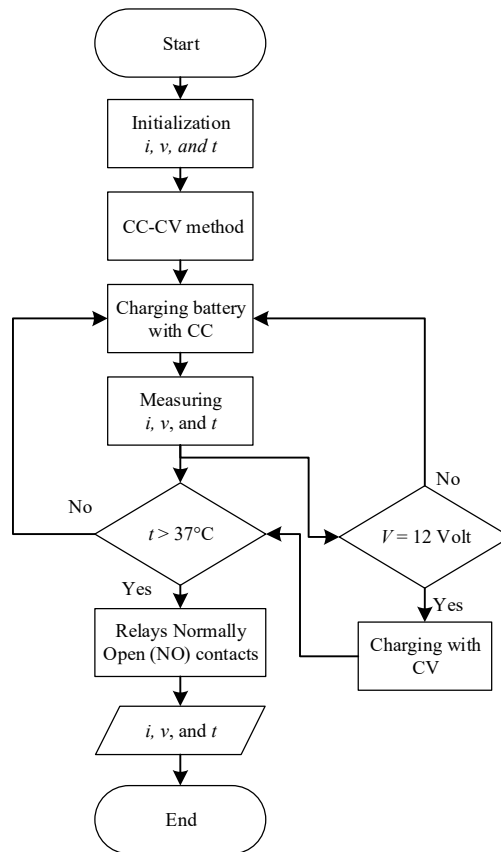

Figure 1. Block diagram of the proposed lead-acid battery charging system.



Gambar 2. Flowchart of the proposed method

### 3. RESULTS AND DISCUSSION

This study evaluates the efficacy of CC-CV method by comparing it against a conventional Switch Mode Power Supply (SMPS) method as a baseline. The evaluation is based on charging speed, the characteristic relationship between charging current and battery voltage, and the relationship between battery temperature and voltage. Tests were conducted on a wet-type Lead-Acid battery, INCOE NS60L, with the following specifications: 45 Ah capacity, 12 V nominal voltage, 13.8 V charging voltage, and a charging current range of 21–30 A.

#### 3.1. Test Results Using the Switch Mode Power Supply (SMPS) Method

The graph illustrates the characteristic charging profile of the lead-acid battery under test using the SMPS method, as depicted in Figures 3 and 4. Testing was performed by measuring the battery voltage from its initial state (before charging) until the charging voltage reached a stable condition (no further change). The results show the battery voltage increased from 11.72 V to 13.4 V over a charging duration of 300 minutes (5 hours). At the beginning of the charge cycle ( $t = 0$ ), the voltage was recorded at 13.4 V with a charging current of 21 A and a battery temperature of 29°C. Over time, the battery temperature rose to 33.2°C. A gradual decrease in charging current was also observed, from 21 A down to 4 A, as the battery voltage approached its maximum (13.4 V).

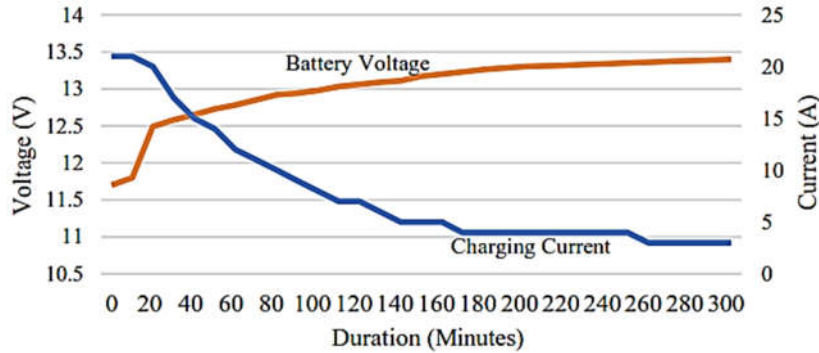

Figure 3. Comparison of battery voltage and charging current characteristics using the SMPS method.

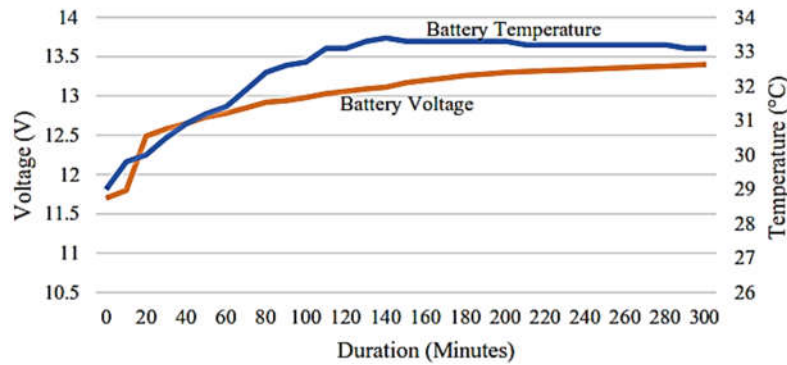

Figure 4. Battery voltage and temperature profiles during SMPS charging

After the charging phase was terminated and a resting period ( $\pm 10$  minutes) was applied, the battery voltage dropped and stabilized at 12.0 V (resting voltage). Measuring the resting voltage after this interval is considered more accurate for representing the battery's true state. A rise in battery voltage generates a corresponding decrease in charging current, as depicted in Figure 3. This inverse relationship is attributed to the increase in the battery's internal resistance during the charging process. Figure 4 demonstrates that extended charging duration correlates with increased battery voltage, a process that subsequently elevates the battery temperature.

### 3.2. Test Results of the CC-CV Method with Temperature Limitation

In this testing, the CC-CV method was employed along with a temperature constraint mechanism integrated into the charging controller. The battery used for the test was an INCOE NS60L wet-type Lead-Acid battery. Prior to the main tests, a calibration process was performed on all sensors (voltage, current, and temperature) of the proposed device. This calibration aimed to minimize measurement errors, ensuring the acquired data had a low error rate and was reliable. Through the application of this method, comprehensive performance data was obtained, including:

1. Charging Speed (Duration).
2. Characteristic Relationship between Charging Current and Battery Voltage.
3. Characteristic Relationship between Battery Temperature and Battery Voltage.

These data sets form the basis for analysing the effectiveness and advantages of the temperature-aware CC-CV method compared to the conventional (SMPS) method.

Overall, the testing of the proposed method demonstrated a well-controlled charging trend: battery voltage and temperature increased proportionally, while the charging current decreased significantly as the battery approached full capacity. The implementation of the temperature-constrained CC-CV method yielded charging characteristics significantly different from the SMPS method, as shown in Figures 5 and 6. The Fast and Controlled Charging Profile is represented in Figure 5.

- **Constant Current (CC) Phase:** The initial period (0-30 minutes) shows the charging current maintained constantly at ~21 A, while the battery voltage rises linearly from ~11.72 V.
- **Transition and Constant Voltage (CV) Phase:** At the 30-minute mark, the voltage reaches the set point of ~12.0 V. The system then transitions to the CV phase, marked by stable voltage and an exponential decrease in current. The current drops sharply to below 5 A within the next 20 minutes.
- **Charging Speed:** The total charging time is only about 130 minutes (2 hours 10 minutes), substantially faster than the 300 minutes required by the SMPS method. This proves the effectiveness of the CC-CV method in accelerating the process without causing overvoltage.

Effective Temperature Management is shown in Figure 6.

- **Thermal Response:** The graph shows that the battery temperature increases gradually alongside the voltage during the CC phase, peaking at approximately 35.5°C.
- **Temperature Stabilization:** After the system enters the CV phase (~minute 30), the temperature rise slows and eventually stabilizes below 36°C. This indicates reduced heat generation as the charging current diminishes.
- **Overheating Prevention:** The maximum temperature remains under the 37°C safety limit. This profile proves that the temperature cut-off algorithm functions as a safety guard while also demonstrating that the CC-CV charging profile itself—with its current-reducing CV phase—contributes to managing temperature rise.

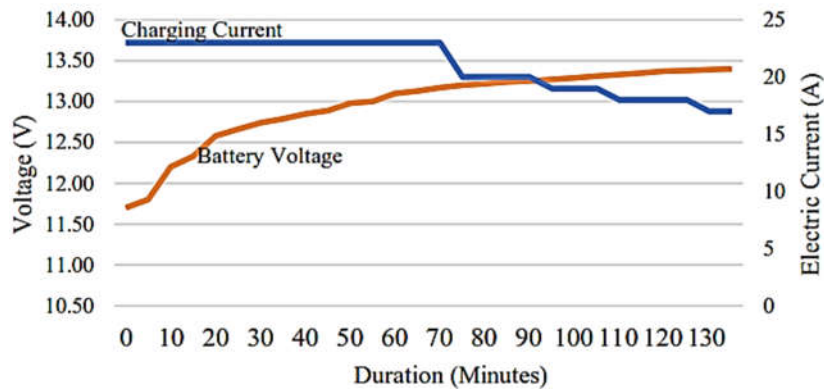

**Figure 5.** Measured battery voltage and charging current during implementation of the proposed CC-CV charging method.

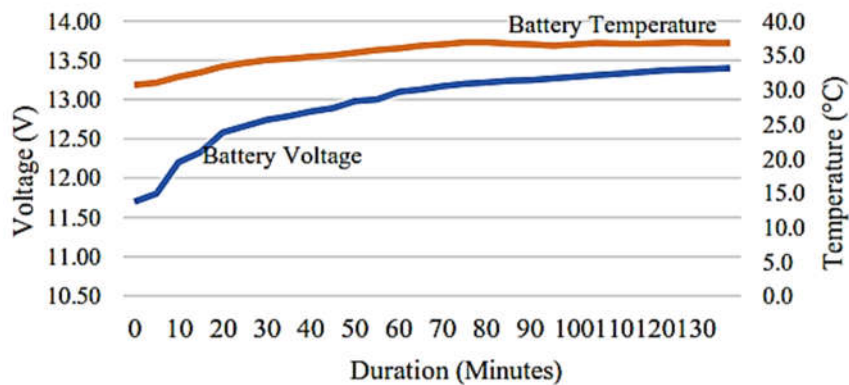

**Figure 6.** Battery voltage and temperature profiles obtained with the proposed charging method.

#### 4. CONCLUSION

The proposed battery charging mechanism, which integrates CC-CV method with temperature monitoring, successfully delivers a faster, more stable, and more efficient charging process compared to the conventional Switch Mode Power Supply (SMPS) method. Quantitatively, the mechanism achieves:

1. A charging time reduction of over 50%, from 300 minutes (SMPS) to just 130 minutes.
2. Effective thermal stability by limiting the maximum battery temperature to  $\approx 35.5^{\circ}\text{C}$ , safely below the  $37^{\circ}\text{C}$  threshold. This success is supported by the optimal CC-CV charging profile combined with the temperature cut-off mechanism.
3. Safe and precise charging completion, evidenced by a distinct change from the CC phase to CV phase, ensuring battery reaches full capacity without overvoltage risk.

Therefore, the temperature-supervised CC-CV method has been validated as a viable solution for enhancing the reliability of level crossing power supply systems, ensuring quicker and more dependable power availability.

Further research is needed to test the durability and performance of battery charging systems using the CC-CV method over a specific time period. Furthermore, this method needs to be applied and tested on various battery types and capacities to determine the reliability, charging stability, and suitability of the method to the characteristics of each battery.

#### ACKNOWLEDGEMENTS

We, as the authors, would like to express our gratitude for the support provided to the PPI Madiun Laboratory Team for their cooperation and technical assistance during the field testing at the level crossing. Thanks, are also extended to the Head of the Railway Electrical Technology Study Program for the permission and institutional support provided.

#### REFERENCES

- [1] S. Lee *et al.*, "Analysing driver behaviour and crash frequency at railway level crossings using connected vehicle and GIS data," *Travel Behaviour and Society*, vol. 39, p. 100957, Apr. 2025, doi: 10.1016/j.tbs.2024.100957.
- [2] S. A. Ibtihal and S. M. Rifaat, "Crash occurrence and severity at railway level crossings in Bangladesh," *Transportation Research Interdisciplinary Perspectives*, vol. 36, p. 101840, Mar. 2026, doi: 10.1016/j.trip.2026.101840.
- [3] N. A. T. Nguyen, L. T. Truong, and R. Skarbez, "Improving nighttime visibility and safety at passive railway level crossings: New designs incorporating photoluminescent markings and signs," *Traffic Injury Prevention*, vol. 27, no. 1, pp. 100–107, Jan. 2026, doi: 10.1080/15389588.2025.2479187.
- [4] Z. Ul Islam *et al.*, "Optimizing hybrid renewable energy based automated railway level crossing in Bangladesh: Techno-economic, emission and sensitivity analysis," *Energy Conversion and Management: X*, vol. 24, p. 100744, Oct. 2024, doi: 10.1016/j.ecmx.2024.100744.
- [5] D. Priyadharshini, R. Yamuna, G. Banu, and S. D. Bensam, "IoT-based Railway Level Crossing Gate Control System," in *2024 Second International Conference on Intelligent Cyber Physical Systems and Internet of Things (ICoICI)*, Coimbatore, India: IEEE, Aug. 2024, pp. 293–297. doi: 10.1109/ICoICI62503.2024.10696415.
- [6] R. Abul Khayr, M. Z. Romdlony, E. Rakhman Priandana, and I. Purnama, "Battery Charging Optimization Using Adaptive Multistage Constant Current–Constant Voltage Method With Multiagent Particle Swarm Optimization," *IEEE Can. J. Electr. Comput. Eng.*, vol. 48, no. 4, pp. 333–339, 2025, doi: 10.1109/ICJECE.2025.3591784.
- [7] J. Kong *et al.*, "Multi-physics-informed fast charging strategy of lithium-ion batteries for aging suppression and thermal safety," *Applied Energy*, vol. 413, p. 127702, Jun. 2026, doi: 10.1016/j.apenergy.2026.127702.
- [8] S. Lavety, R. K. Keshri, and M. A. Chaudhari, "Multistep Constant Current-Constant Voltage Charging Strategy for a Valve Regulated Lead-Acid Battery," *IEEE Trans. on Ind. Applicat.*, vol. 57, no. 6, pp. 6494–6503, Nov. 2021, doi: 10.1109/TIA.2021.3113268.
- [9] X. Cui, Z. Zhang, G. Tang, and H. Zhang, "Seamless Switching Control Strategy for Diesel Generator and Energy Storage Hybrid Emergency Power Supply System," in *2018 2nd IEEE Conference on Energy Internet and Energy System Integration (EI2)*, Beijing: IEEE, Oct. 2018, pp. 1–6. doi: 10.1109/EI2.2018.8582311.
- [10] J. Niveditha, T. Venkatesh, A. Reethika, U. Ramya, S. Sreejaa, and V. Vinothini, "An Efficient, Affordable and Reliable SMPS Battery Chargers for Automobile Industry," in *2024 2nd International*

- Conference on Advances in Computation, Communication and Information Technology (ICAICCIT)*, Faridabad, India: IEEE, Nov. 2024, pp. 1198–1202. doi: 10.1109/ICAICCIT64383.2024.10912110.
- [11] M. Nivetha and I. Karuppasamy, “A Comparative Simulation Study on State of Charge Estimation for 48 V Lithium-Ion EV Battery Packs: Insights from CV and CC-CV Charging Techniques,” in *2025 IEEE 6th India Council International Subsections Conference (INDISCON)*, Rourkela, India: IEEE, Aug. 2025, pp. 1–6. doi: 10.1109/INDISCON66021.2025.11254772.
- [12] M.-S. Karbasforooshan, “Modeling, Design and Control of a Power Factor Correction Converter for a Switch-Mode Power Supply to Electric Power Quality Improvement,” in *2025 29th International Electrical Power Distribution Conference (EPDC)*, Tehran, Iran, Islamic Republic of: IEEE, Oct. 2025, pp. 1–6. doi: 10.1109/EPDC67173.2025.11278307.
- [13] W. Huang, M. Jiang, H. Liu, and Y. Chang, “Research on constant current and constant voltage charging in frequency switching wireless power transfer systems,” *Electric Power Systems Research*, vol. 253, p. 112537, Apr. 2026, doi: 10.1016/j.epsr.2025.112537.
- [14] J. M. A. Freire, J. J. Lado, G. Castro, E. Longhinotti, E. García-Quismondo, and J. Palma, “Enhancing capacitive deionization performance through a hybrid constant current-constant voltage operational mode,” *Separation and Purification Technology*, vol. 364, p. 132348, Aug. 2025, doi: 10.1016/j.seppur.2025.132348.
- [15] J. Liu, J. Gao, and Q. Zhao, “A dual-coupled LCC-S-compensated inductive power transfer system with constant current and constant voltage outputs,” *Computers and Electrical Engineering*, vol. 127, p. 110537, Oct. 2025, doi: 10.1016/j.compeleceng.2025.110537.
- [16] S. Baradari, N. Alyasin, and D. N. Esfahani, “Preventing premature aging in valve-regulated lead-acid batteries: Optimal charging strategies to mitigate sulfation,” *Next Research*, vol. 2, no. 3, p. 100659, Sep. 2025, doi: 10.1016/j.nexres.2025.100659.
- [17] M. Alipour and H. Nasserri, “Investigating the effect of charging voltage on the large-scale recovery of valve-regulated lead-acid batteries beyond their storage life: a real case report,” *Next Research*, vol. 2, no. 3, p. 100399, Sep. 2025, doi: 10.1016/j.nexres.2025.100399.